

Board to Board (FPC) Connectors

0.8mm Pitch Board to Board Connectors: PB-8 Series

■ Features

1. Plugs are available in straight and right-angle type .
2. Non-pin type structure assures easy, light insertion.

*Products in the product list are listed with part numbers without hold-downs.
For part numbers with hold-downs, please contact us.

■ Specifications

- Pitch : 0.8mm
- Mating Height : 4.5mm(Straight Type), 6.05mm(Right-Angle Type)
- Width : 4.7mm(Socket),5.1mm(Straight Plug), 5.05mm(Right-Angle Plug)
- Number of Pins : 10, 12, 14, 16, 18, 20, 22, 24, 26, 28, 30, 32, 34, 36, 38, 40, 48, 54 (except for Straight plugs 24, 32, 34, 38, 40)
- Rated Voltage AC/DC : 50V AC/DC, 0.5A
- Contact Resistance : 20mΩ max.
- Insulation Resistance : 100MΩmin. at 500V DC
- Withstanding Voltage : 500V AC (for one minute)
- Operating Temperature Range : -30°C to +85°C

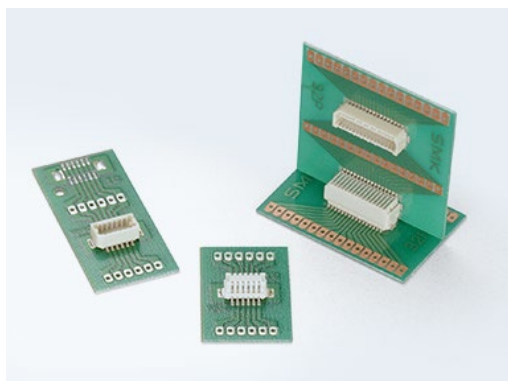

Plug (Straight Type) : CPB82□□-0411F

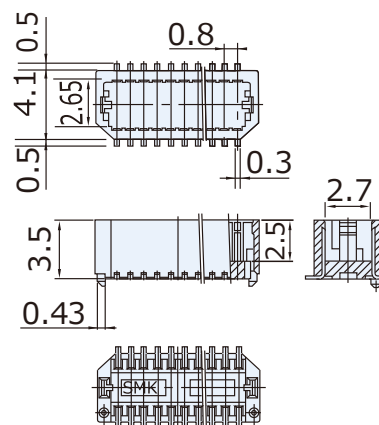

Plug (Right Angle Type) : CPB83□□-0411F

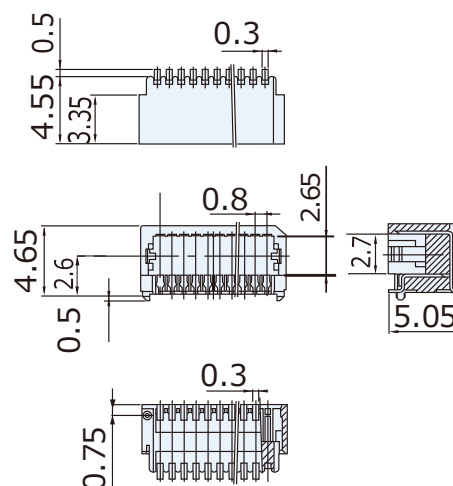

Socket : CPB81□□-1611F

