

# Mini Jacks

## 2.5mm Dia. Jack : JK-25 series

### ■ Features

1. It is a small jack with a diameter of 2.5 mm.
2. SMD and DIP types are available.

### ■ Specifications

- Applicable Plug Diameter :  $\phi 2.5\text{mm}$
- Number of Pins : 3,4
- Mounting Style : SMD, DIP
- Rated Voltage AC/DC : 12V DC, 1A
- Contact Resistance : 30m $\Omega$  max.
- Insulation Resistance : 100M $\Omega$  min. at 500V DC
- Withstanding Voltage : 500V AC (for one minute)



**LGK1709-1601F**

SMD Type

Circuit

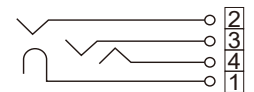
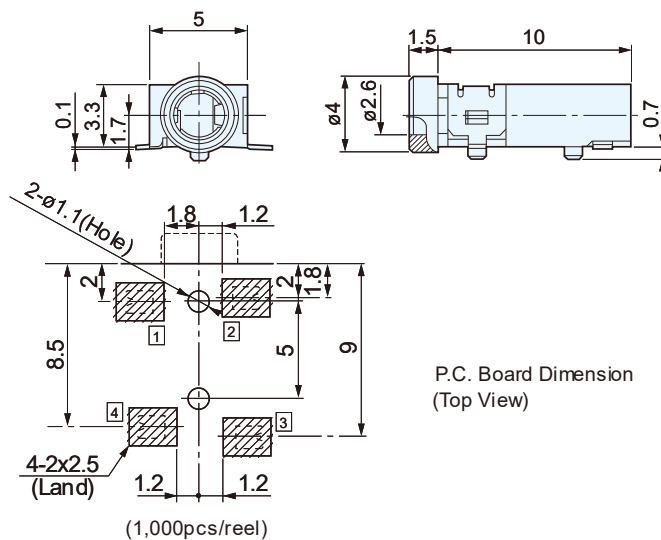

Reflow soldering

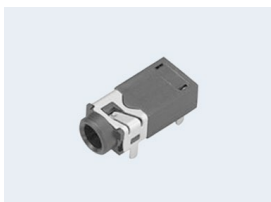

**LGK1709-2200F**

DIP Type

Circuit

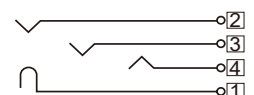
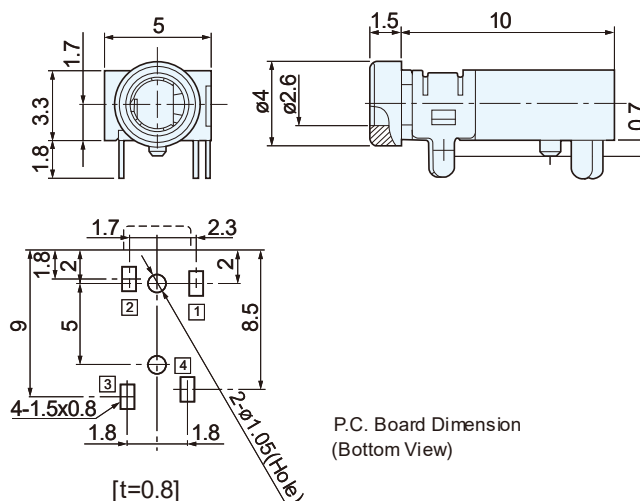

Manual soldering

