

Slide Switches

JSB Series :Slide Switches

■ Features

1. Small size switches of 2mm terminal pitch and 2mm stroke good for high density mounting
2. Switches are ultra thin type of 2mm height from the mounted surface of PC boards.
3. Insulation materials using high heat-resistant resin increase the heat resistance characteristic and reliability. (JSB1220-1721F)

■ Specification

- External Dimension :11.8 x 2.7 x 2 mm (JSB1320-0101, JSB1320-0201)
- Rating :0.1A, 12V DC
- Circuit :SP3T (JSB1320-0101, JSB1320-0201)
- Operating Life :10,000 cycles
- Operating Force :1.5N
- Travel :2.0mm



JSB1320-0101

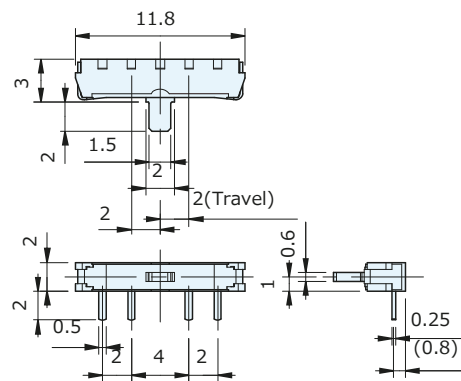

Circuit : SP3T

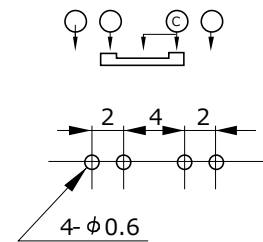

P. C. Board Dimension



JSB1320-0201

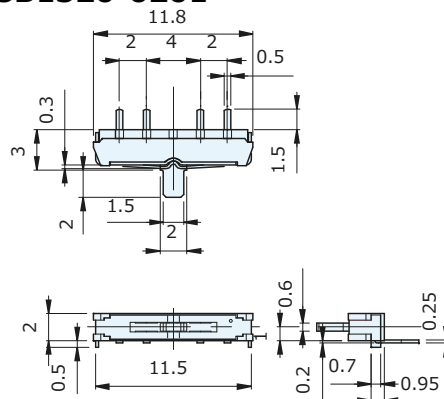

Circuit : SP3T

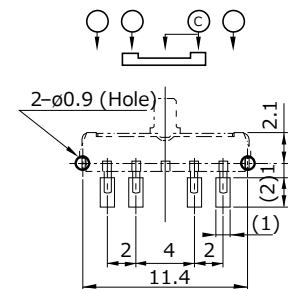

Mounting Mode